



# BEVERAGE-AIR

Project: _____	AIA#
Item: _____	
Location: _____	SIS#
Approved: _____	

**WTF60AHC WORKTOP FREEZER**

## WORKTOP FREEZER

### WTF60AHC Solid Door Freezer

### Hydrocarbon Series

**MODEL:**  
**WTF60AHC**



**5 Year Parts/Labor Warranty Available**  
**7 Year Compressor Warranty**

#### CABINET CONSTRUCTION

- Stainless steel front, sides, doors and grille (galvanized back & bottom)
- Interior liner is made of corrosion resistant aluminum
- Stainless steel top for added durability
- 4" Removable backsplash for flexibility and ease of cleaning
- Full electronic control
- Interior thermometer is standard
- Self-closing doors with 120° stay-open feature, on cartridge style hinges
- Door opening includes low wattage, anti-condensate heaters
- Magnetic gasket attached to each door for positive seal
- 6" Casters, two (2) with brakes standard
- Four (4) epoxy-coated steel wire shelves
- Field-reversible doors (hinge kit not included)

#### OPTIONS & ACCESSORIES

- 3 Year parts/labor standard, additional 2 year warranty available
- Stainless steel back
- Stainless steel interior
- 16 Gauge stainless steel top
- Additional shelves
- Shelf clips
- Glass door option
- Right or left hinged door
- Locks (solid doors only)
- Bun rack
- Wire shelf divider
- Cutting board
- 3" Casters
- 6" Legs (stainless steel, black or seismic/flange)
- Low profile casters
- Roller kit
- Remote option\* (see note on back on page)

#### REFRIGERATION SYSTEM

- Uses environmentally friendly, energy efficient R290 refrigerant, and meets all regulatory requirements for CARB, SNAP, DOE & more
- Adaptive defrost
- Epoxy coated evaporator coil
- Freezers capable of maintaining product temperature of -10°F



  
Please verify qualifying units by visiting:  
[www.energystar.gov/cfs](http://www.energystar.gov/cfs)

3779 Champion Blvd., Winston-Salem, NC 27105  
1-888-845-9800 Fax: 1-336-245-6453  
Beverage-Air.com Sales@bevair.com



# BEVERAGE-AIR

MODEL	WTF60AHC
<b>EXTERNAL DIMENSIONAL DATA</b>	
Width Overall	60"
Depth Overall with Handle & Bumper	32"
Height Overall with 6" Casters	39 <sup>5</sup> / <sub>8</sub> "
Number of Doors	2
Depth with Door Open 90°	55 <sup>1</sup> / <sub>4</sub> "
Door Openings	22 <sup>5</sup> / <sub>8</sub> " x 21 <sup>5</sup> / <sub>8</sub> "
<b>INTERNAL DIMENSIONAL DATA</b>	
NET Capacity (cubic ft.)	14.39
Internal Width Overall (in)	56"
Internal Depth Overall (in)	15 <sup>3</sup> / <sub>8</sub> "
Internal Height Overall (in)	23"
Number of Shelves	4
<b>ELECTRICAL DATA</b>	
Full Load Amperes	5.0
<b>REFRIGERATION DATA</b>	
Horsepower	1/2
Capacity (BTU/Hr)	1861
Heat Rejection (BTU/Hr)	2791.5
Charge (lbs/grams)	0.165/75
<b>SHIPPING DATA</b>	
Gross Weight - Crated	320 lbs
Height - Crated	36"
Width - Crated	63"
Depth - Crated	33"

\*NOTE: Remote units are field wired and come with 6" legs. Refrigerant must be specified at time of order.

## Worktop Freezer Model: WTF60AHC

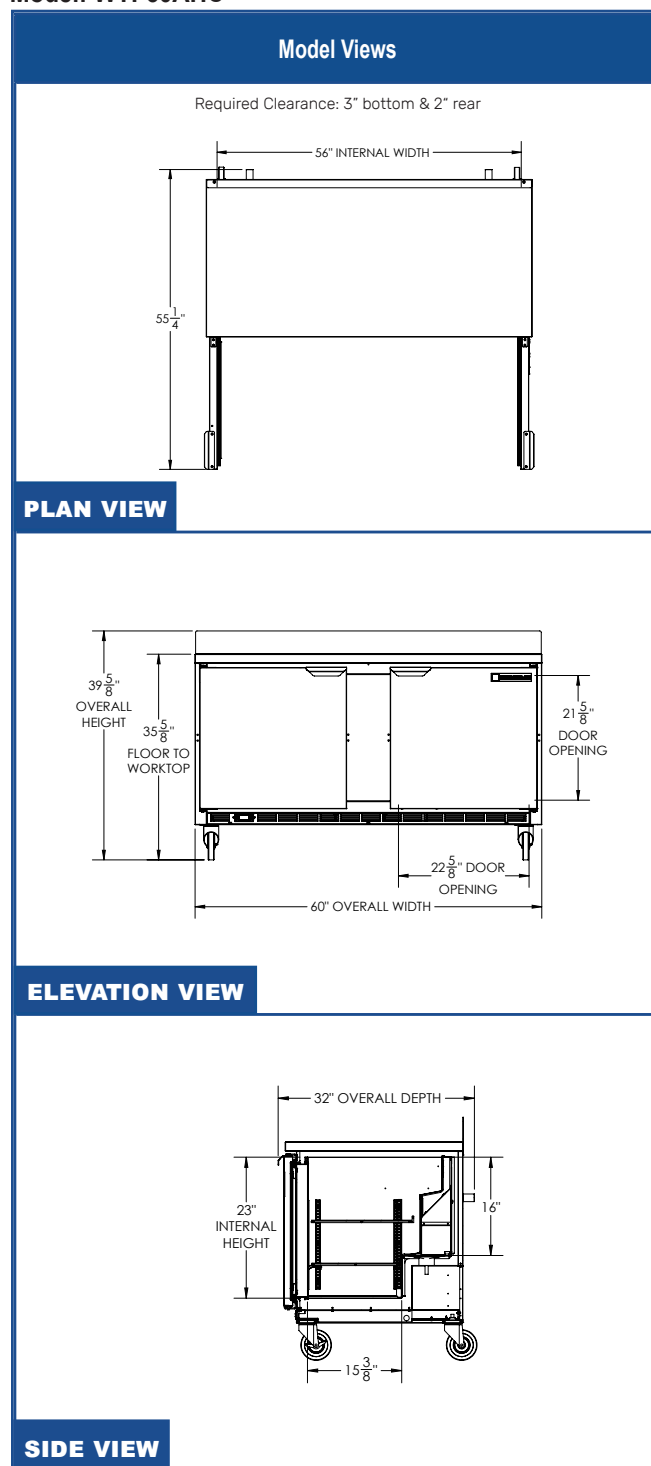

### ELECTRICAL CONNECTION



115/60/1  
NEMA 5-15P

Unit pre-wired at factory and include 8' long cord and plug set.